

# ***BACKFLOW PREVENTION AND PRACTICE STUDY GUIDE***

*Written by: The Cross-Connection Control Backflow Prevention Sub-Committee of  
The NC AWWA / WEA School Committee  
Revised: Feb. 24, 2003*

Table of Contents

INTRODUCTION TO BACKFLOW PREVENTION ..... 1

    BACKFLOW / CROSS-CONNECTIONS ..... 5

    NON-POTABLE SOURCE / CONTAMINANT / POLLUTANT ..... 6

    BACKFLOW / BACKSIPHONAGE ..... 6

    BACKFLOW PREVENTION ..... 7

HAZARDS OF BACKFLOW ..... 9

    TYPES OF CONTAMINANTS ..... 9

        BIOLOGICAL ..... 9

        CHEMICAL ..... 9

FUNDAMENTALS OF BACKFLOW ..... 10

    CROSS - CONNECTIONS ..... 10

        TYPES: ..... 10

            TEMPORARY ..... 10

            PERMANENT ..... 11

        WHY CROSS-CONNECTIONS ARE CREATED ..... 12

    UNDERSTANDING BACKFLOWS ..... 13

        PRESSURE PRINCIPLES ..... 13

            ATMOSPHERIC PRESSURE ..... 13

            GAUGE PRESSURE ..... 14

            ABSOLUTE PRESSURE ..... 14

        WATER: UNDER STATIC CONDITIONS ..... 16

        WATER MOVEMENT ..... 16

        BACKSIPHONAGE ..... 17

        BACK PRESSURE ..... 18

        CAPILLARY ACTION ..... 19

    SUMMARY ..... 20

METHODS FOR PREVENTING BACKFLOW ..... 21

    BACKFLOW PREVENTION METHODS ..... 21

    MECHANICAL BACKFLOW PREVENTERS ..... 23

    APPROVAL of BACKFLOW PREVENTION DEVICES ..... 24

        PRESSURE VACUUM BREAKER ..... 25

        DOUBLE CHECK VALVE ASSEMBLY ..... 27

        REDUCED PRESSURE PRINCIPLE ASSEMBLY ..... 28

    Unapproved Devices ..... 29

        ATMOSPHERIC VACUUM BREAKER ..... 31

    SUMMARY CHART OF BACKFLOW PREVENTION METHODS ..... 33

    SUMMARY ..... 33

    SUMMARY OF BACKFLOW PREVENTION METHODS CHART BLANK ..... 36

    SUMMERYOF APPLICATONS FOR INTERNAL BACKFLOW PROTECTION ..... 37

GLOSSARY ..... 39

North Carolina Section AWWA/WEA Approved Backflow Prevention Assembly Field Test Procedures ..... 44

# INTRODUCTION TO BACKFLOW PREVENTION

## PURPOSE AND SCOPE

Public Law 93-523 which established the Safe Drinking Water Act was approved and passed in 1974. This Law states that the water purveyor is responsible for the integrity of the water supplied from the distribution system. The intention of the act of 1974 is to designate the water purveyor as the prime entity responsible for the quality of water to the further most point, or last free flowing tap of the distribution system and to establish maximum contaminant levels at that point. However, the Act does not imply that the water purveyor is in anyway responsible for the customers plumbing system.

In North Carolina, the Department of Insurance enforces building codes. Volume II of the North Carolina State Building Code, Appendix D, Subsection 102.4, states that, "The consumer has the prime responsibility of preventing contaminants and pollutants from entering the water supply system, and from entering the public water mains or water source from his water supply system. The Consumer shall protect his supply system against actual or potential cross connections..." A cross-connection that exists inside a private building could potentially allow backflow of hazardous materials into the drinking water supply. If a backflow of contaminants at levels above those allowed by federal or state regulations entered the drinking water system within the building, the consumer would not receive water that would meet Federal drinking water standards, which could leave the purveyor responsible.

A question that must be addressed is: Does the water purveyor's responsibility end at the water meter (the point of delivery from purveyor to customer) or at the point of use? Unfortunately, there is no definitive answer. Each water purveyor must examine this question and determine what is "reasonable and prudent" for their situation. When considering the components of a good backflow prevention program, one must keep in mind what can be achieved financially. The cost of running a quality program is greatly affected by current and upcoming governmental policies and/or procedures. One should keep in mind the goal of "providing safe drinking water", as required by federal, state, and local laws. Local laws should take precedence over all other factors involved. A full-fledged backflow prevention and cross-connection control program is recommended. The water purveyor should remember to consider the costs of litigation that could ensue because of a backflow. For many water purveyors, the development of a program is achieved in a series of steps, implementing what is possible under current financial constraints and expanding the scope of the program, as more funds are made available. It is imperative to remember that each water purveyor has the ultimate responsibility to protect the water in its distribution system from being contaminated or polluted!

Often the first goal in a program is to achieve backflow containment in the municipal system. Containment is when backflow preventers are installed down stream of the meter before any branching or before point of use, in order to contain any contaminants on the consumers' system. Beginning a containment program involves surveying present customers facilities in order to determine what degree of hazard

exists within their facility. Knowing this information will help the water purveyor to ensure that the appropriate backflow prevention assembly is incorporated into the supply line serving the facility's water system. The municipality/purveyor may require the consumers to install the required assembly or choose to perform the retrofit themselves, depending upon what is stated in the purveyor's ordinance or regulation. Remember that the water purveyor is the authority primarily responsible for preventing cross-connections and therefore is also responsible for inspecting facilities on the water system to ensure compliance with all regulations.

Another approach the water purveyor can take is isolation. The isolation method provides a backflow preventer at each cross connection found within the customers' facility. New, as well as existing plumbing systems are surveyed for cross-connections, with backflow preventers being installed at each potential point of contamination. One should especially note that existing facilities (which are normally exempt from inspection under the plumbing code's grandfather clause) are **not** exempt from cross-connection control inspections, since cross-connection control is a health issue, and water quality can be affected by either new or existing structures. Those interested in pursuing this approach should be cautioned that routine re-inspections, as well as annual testing of the backflow prevention assemblies is imperative if this method of cross-connection control is to be truly effective. One problem that arises with this method is that alteration of plumbing can easily create new cross-connections or recreate old cross connections. Ultimately, this must be controlled through a routine inspection and testing program. The isolation approach is best accompanied by the containment approach as well. It is also best that the containment approach be the minimum level of protection that is considered.

**The purpose of this course is to provide the necessary training and education to those who design, alter, install, or inspect potable and non-potable water supply systems. The two approaches of backflow prevention and cross-connection control are presented as the means of preventing backflow hazards.**

Backflow prevention deals with hydraulics (the physical conditions that allow backflow events to occur), and the utilization of means for eliminating physical conditions and mechanisms that can be used to prevent backflow. Cross-Connection control involves inspection and surveying programs designed to identify and eliminate cross-connections, which prevents the potential for a hazardous backflow incident.

Because backflow prevention assemblies have a limited life span and because plumbing is installed and altered frequently, a backflow prevention program will not be effective if a "fix-it and-forget-it" philosophy is adopted. An ongoing program that includes testing, and monitoring a backflow prevention assembly's performance is necessary. Continuing education is also essential to adequately educate the public on how to prevent the occurrence of backflow. **Education is the most important element of a cross connection control program!**

An effective backflow prevention program **must include seven essential components:**

Legal Authority...Must exist at the local level (in the form of an ordinance).

Plan Review of New Construction

Utilization of Standards and Specifications to delineate "Approved" Backflow Prevention Assemblies

Testing and Maintenance of installed backflow prevention assemblies.

Record Keeping

Program for Surveying and Retrofitting Existing Facilities

**Training of Utility Personnel and Education of Water Consumers and Others Involved in Backflow Prevention**

Several North Carolina backflow incidents will be used in this guide to introduce the topics of backflow and cross-connections. Later we will more thoroughly discuss how cross-connections are created, how backflow occurs, and the impact that backflow can have on the public health.

On April 24, 1986, the Fayetteville Times reported that a pesticide contaminated what appeared to be a "small" part of the Hope Mills water system, prompting the town to warn residents of about 23 households not to drink their water. Authorities believe the problem occurred when a waterline broke along North Main Street. Workers from a pest control service were filling one of their pesticide truck tanks with water when the break occurred and pressure in the waterline was reduced, causing material from inside the tank to be sucked into the building's waterline and out to the town's water main. The pesticide, containing the chemicals chlordane and heptachlor, contaminated what appeared to be a small portion of the town's water supply. A device (Hose Bib Vacuum Breaker) on the outside water faucet designed to protect the building's water system from such an incident malfunctioned.

On December 7, 1974, in a moderate size city in North Carolina, a major fast food chain restaurant received complaints of a bitter taste in the soft drinks they were selling. Over 300 people were served soft drinks during the period in question. Syrups were changed several times but to no avail. The local water department was notified and an investigation was immediately started. The local water department traced the problem to a chemical in the water and determined this particular chemical was used to treat boiler water in a fertilizer plant, located one-half mile away from the restaurant. Investigation at the fertilizer plant revealed that a check valve on the supply line to the boiler was leaking and allowed the chemical in the boiler to backflow into the street main supplying the restaurant.

## BACKFLOW / CROSS-CONNECTIONS

In order to understand how these incidents could have occurred, a better comprehension of the events and conditions that cause backflow is needed. Technically, **backflow is a reversal of the normal flow of a liquid or gas.** A potentially hazardous backflow can occur whenever a cross-connection exists. A **cross-connection is a link between a potable water system and a non-potable system. Potable water is both safe for consumption and is aesthetically pleasing, whereas, a non-potable system is of questionable quality.**

In the Fast Food Chain Restaurant backflow incident, a direct, permanent cross-connection provided a physical link between the drinking water supply and the non-potable source. In this case the boiler containing the contaminant and the pipes containing drinking water were directly connected to one another; only a check valve prevented the free flow of the contaminant into the potable drinking water. When this check valve failed, the contaminant back flowed into the potable water system.

In the Hope Mills backflow incident, a hose created the cross-connection. Whenever a hose is connected to a faucet, it becomes a temporary extension of the potable water system. If the outlet of the hose was submerged in the pesticide, a temporary, indirect cross-connection between the potable drinking water system and the tank containing the insecticide would be created. This physical link between the potable system and the non-potable source provides a pathway that will allow movement in either direction. Normally the pressure maintained in the potable water system will cause water to flow from the potable water system into the non-potable source. However, any event that substantially reduces the potable line pressure can create conditions where the non-potable source will backflow into the potable system.

## NON-POTABLE SOURCE / CONTAMINANT /

### POLLUTANT

A **non-potable water source or system** can be loosely defined as any liquid, gas, or other substance that when diluted, dissolved, suspended, or mixed in water adversely affects the quality of the water. A non-potable substance can be classified as either a "**health hazard**" or a "**non-health hazard**".

A substance is a health hazard (high hazard) if it can adversely affect human health and safety. The introduction of a **contaminant** into the potable water system creates a health hazard. Obviously, both the insecticide and the chemicals could be considered contaminants. Most insecticides are toxic and many are deadly if ingested in sufficient quantities. Contamination is defined as the impairment of the quality of water to a degree that human consumption could result in poisoning or the spread of disease.

Obviously, non-health hazards (low hazards) do not affect public health, but they do affect the aesthetic quality of the drinking water. The introduction of a **pollutant** such as iron into the potable water system creates a non-health hazard. Iron is an essential vitamin that many people do not consume in sufficient quantities; however, it can become a nuisance if elevated levels are found in potable water as it may stain laundry and plumbing fixtures. Sulfur is another example of a pollutant. At low levels, sulfur is non-toxic even though it creates a very vile rotten-egg odor. However, sulfur can also be a contaminant, and at very high levels it is toxic and becomes a health hazard. Pollution is defined as the presence of any foreign substance (organic, inorganic, radiological, or biological) in water that tends to degrade the quality of such water so as to constitute a hazard or adversely affects the usefulness of the water.

### BACKFLOW / BACKSIPHONAGE

There are two types of backflow: **back pressure and back-siphonage**. Backpressure is defined to be any pressure, which works against, and may override the pressure generated by the public water supplier. Backpressure occurs when the non-potable source pressure exceeds the potable water pressure. This can occur through a rise in the non-potable pressure, a drop in the potable pressure, or a combination of both.

Increases in non-potable pressure above potable water system pressure can be created by booster pumps, equipment that allows for extreme temperature increases (e.g. a boiler), elevation differences, and so forth.

A reduction in the potable water supply pressure can occur whenever water use (demand) exceeds the amount being supplied by the water purveyor. Examples of



heavy water use include water line flushing, fire fighting, or breaks in water mains. Smaller water demands, such as small water line breaks, can reduce the supply line pressure sufficiently to create a backflow.

The second type of backflow is known as **back siphonage**. Back siphonage occurs when the supply line pressure falls below atmospheric pressure (14.7 psi at sea level). In this situation, atmospheric pressure is creating a greater pressure on the non-potable system side in the reverse direction of flow than the potable water system is maintaining in the normal direction of flow. Atmospheric pressure on the non-potable side forces a reversal of flow. Back siphonage is similar to back pressure situations where the potable system pressure drops. **However, for a backflow incident to be termed back siphonage, the potable system pressure must fall below atmospheric pressure.** Thus, events that cause backpressure by reducing potable side pressure (e.g., fire fighting) can also cause back siphonage. Normally, atmospheric pressure on the potable side would balance the effect of atmospheric pressure on the non-potable side. However, a large demand such as a fire fighting actually creates a vacuum in the potable water lines, thus, the pressure falls below 14.7 psi allowing back siphonage to occur.

In the Hope Mills incident, there was a reduction in the city's water supply pressure below atmospheric pressure. Atmospheric pressure then pushed the toxic mixture of pesticide and water into the hose and up into the potable water line.

In both incidents, a **pressure differential** occurred such that the water pressure on the potable side was lower than the pressure on the non-potable side. Backflow can occur whenever a pressure differential exists and a cross-connection provides the link between the two sources.

## **BACKFLOW PREVENTION**

Because of the major impact backflow can have on public health, it is important that backflow be prevented. The single most significant problem hampering the elimination of cross-connection and prevention of backflow, is that little has been done to educate the water **consumer** about the problems associated with backflow. While many water purveyors recognize that they could be judged negligent if they do not take action to protect the public water supply from a backflow incident, the 1975 National Interim Primary Regulations state: "contaminants added to the water under circumstances controlled by the user... are excluded from the definition of maximum contaminant". This has been interpreted (by legal precedent) to mean that consumers are legally liable for their own actions. However, few consumers are aware of their responsibilities, and individuals who are unaware of the hazards of backflow inadvertently create most cross-connections.

In fact, many states have done little to educate **any** of the people involved: water purveyors, water distribution personnel, plumbers, plumbing inspectors (building inspectors), engineers, plumbing contractors, irrigation contractors, heating/cooling

contractors, wastewater operators, home owners, handymen, or virtually any other individual in a position to tap into or alter a potable water line for any purpose. (Recall that an alteration can be as simple as connecting a hose to a faucet).

Even if individuals are familiar with the inherent dangers of cross-connections, they may accidentally create them if they do not fully understand the hydraulic conditions that cause backflow, or if they have not had adequate training in the proper installation and maintenance of backflow prevention assemblies. Moreover, many individuals intentionally install cross-connections out of convenience. For instance, those who are not aware of the significant advantages in backflow prevention assemblies might install an inadequate device instead of the appropriate form of protection because they unjustly fear that the appropriate device would significantly reduce line pressure. The problem is further compounded if plumbing installations are not inspected, or if plumbing inspectors are not adequately trained in backflow prevention. Therefore, **education** is essential to the elimination of cross-connections and the prevention of backflow.

# HAZARDS OF BACKFLOW

## TYPES OF CONTAMINANTS

### BIOLOGICAL:

Biological agents can be classified as either pollutants or contaminants. **Biological pollutants** are agents that do not cause disease but do decrease the aesthetic quality of the water. Maintaining the aesthetic quality of the water is important from a public health viewpoint, because if the water is not aesthetically pleasing, the water users may convert to an alternate water source that may not be safe. In addition, biological pollutants can interfere with the water treatment process. Ultimately, treatment costs for combating biological pollutants will continue to rise.

**Biological contaminants** are agents that can cause disease. There are a number of different biological agents (bacteria, viruses, protozoan, algae, etc.) that can cause disease. Any biological agent that is primarily spread through water is classified as a **waterborne disease**.

A single backflow incident can potentially affect hundreds or even thousands of people. The larger the water distribution system is, the greater the potential for a single backflow incident to affect a large number of people. Other factors that determine how many people will be affected by a biological backflow incident include: (1) Detection time (i.e. how quickly it is determined that a backflow has occurred). (2) The onset time of the disease, (3) the pathogen type and virulence of the organism, as well as, the susceptibility of the exposed individual, and (4) the survival time of the biological agent.

### CHEMICAL:

Chemical, like biological agents, can be classified as being either a contaminant or pollutant. **Chemical pollutants** are substances that do not pose a public threat, but reduce the aesthetic quality of the water. Therefore, they are non-health hazards (or low hazards). Like biological agents, any chemical that affects the color, odor, or taste of water is considered to be a pollutant.

**Chemical contaminants** are substances that pose a threat to public health. Therefore, chemical contaminants are health hazards (or high hazards). Inorganic chemicals are metals or other compounds that do not contain carbon, whereas, organic chemicals are substances containing carbon. Organic chemicals are often derived from vegetable or animal matter.

# FUNDAMENTALS OF BACKFLOW

## CROSS - CONNECTIONS

Cross-connections are the physical links that allow backflow. If cross-connections **do not** exist, then the backflow of contaminants and/or pollutants into the potable water supply cannot occur. Therefore, it is important to identify how and why cross-connections are created.

### TYPES:

Cross-connections can be divided into two groupings where they are classified as being:

- (a) Temporary / indirect
- (b) Permanent / direct.

### TEMPORARY/INDIRECT

Examples of temporary cross-connections are shown in figures one and two below. Temporary cross-connections can easily be created when water from the potable water system is utilized for the purpose of diluting chemicals in tank trucks, or when the tank is rinsed out or filled (figure 1). Swing connections, spools, and changeover devices can also form a temporary cross-connection (figure 2). Hoses are believed to be the most common temporary cross-connection.

FIGURE - 1

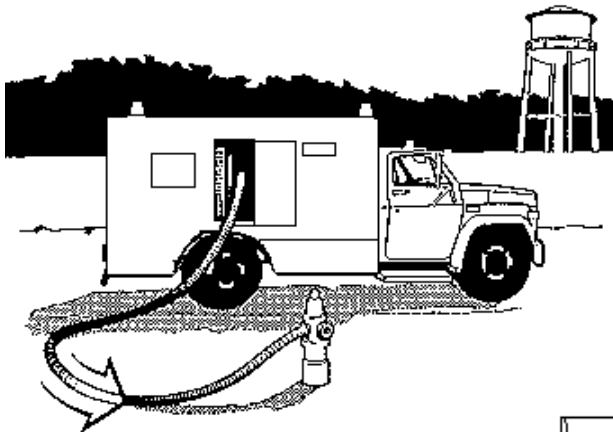
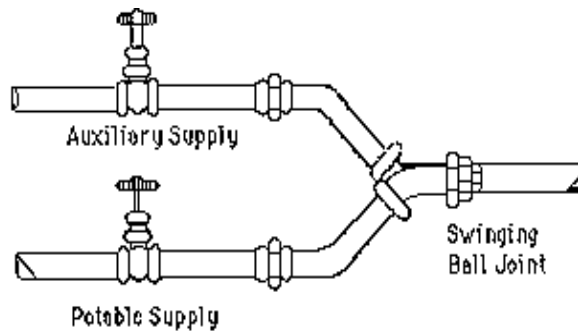

FIGURE - 2



## PERMANENT/DIRECT

Permanent cross-connections are generally created by rigid pipe connections. For instance, a cross-connection is created whenever water is supplied to a boiler, an air-cooling system, or any piece of equipment or holding vessel that by its design could allow pollution or contamination of the potable water supply. However, a hose can also create a permanent cross-connection if it is used as a fixed extension of a water system.

Cross-connections can also be classified as direct or indirect. **Direct** cross connections are generally hard pipe connections, thus they always have the potential for backflow. For instance, the example where water is supplied to a boiler is a direct cross-connection. Often, the terms permanent and direct are used synonymously, but this is not always valid. For instance, an old fashioned bathtub (figure 3) creates an **indirect** - permanent cross-connection. Obviously, the plumbing creates a permanent cross-connection, and it is indirect because a cross-connection is only created if the tub is overfilled and the water inlet becomes submerged. Hoses are also often considered indirect cross-connections; therefore, the terms temporary and indirect are often used interchangeably.

FIGURE - 3

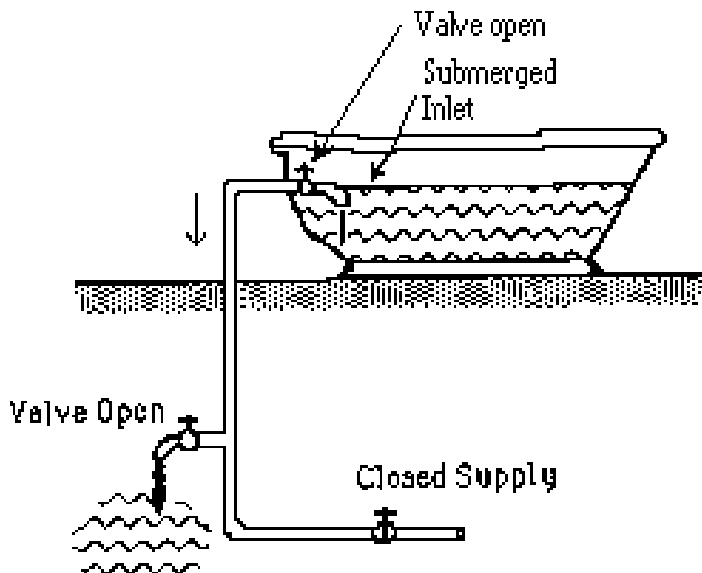

## WHY CROSS-CONNECTIONS ARE CREATED

Some cross-connections are created out of necessity. For instance, a direct cross-connection may be created because it is essential that water be directly and continuously supplied to a boiler. Likewise, some laboratory equipment, food processing equipment, and air-to-water heat exchangers also need a direct and continuous supply of water. Although necessary, any of these direct cross-connections can allow backflow unless the appropriate backflow preventers are put in place.

Other cross-connections are created for the sake of convenience rather than for necessity. Oftentimes, the creator of a cross-connection is not aware of the hazards associated with a cross-connection due to an unawareness about the hydraulic conditions that allow cross-connections to occur or the means available for their prevention. An example of such a cross-connection is shown below (figure 4).

FIGURE - 4

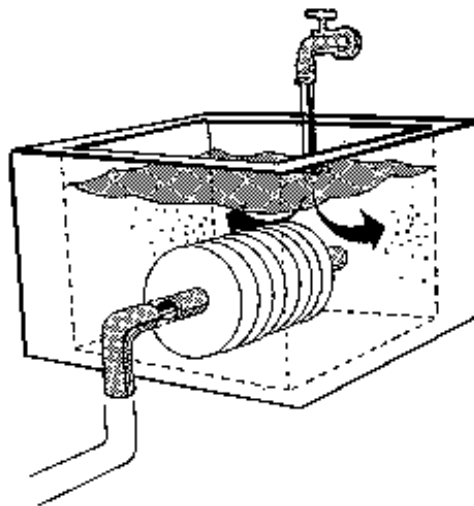

### **Cross-connection**

**created at a Swimming Pool-** The pool operator has extended the water outlet through the use of a hose down into the filter tank to prevent potable water (“make-up water”) from splashing the media off the filters when it is added to the tank. The hose is an extension of the potable water system, and the pool water is now cross-connected to the potable water supply. Water treatment facilities often have similar cross-connections.

# UNDERSTANDING BACKFLOWS

## PRESSURE PRINCIPLES

Backflow hazards occur when water moves through a cross-connection in a direction in which it was not intended to flow. The flow reversal is caused by a pressure differential.

### ATMOSPHERIC PRESSURE:

Pressure is a measurement of **force**. Force is any kind of push or pull, but perhaps the most significant type of force is weight. **Atmospheric pressure** is the force caused by the weight of the atmosphere above the earth. At sea level, atmospheric pressure is 14.7 pounds per square inch (psi). This means 14.7 pounds of pressure is being exerted on every square inch of surface area.

FIGURE - 5

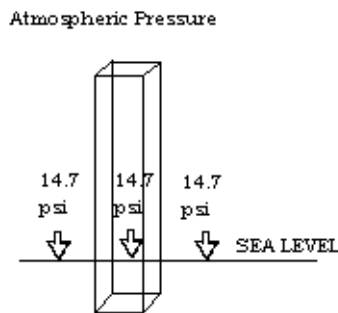

At higher elevations, atmospheric pressure is slightly less, because there is slightly less atmosphere exerting pressure on the surface. Atmosphere pressures at various altitudes are:

FIGURE - 6

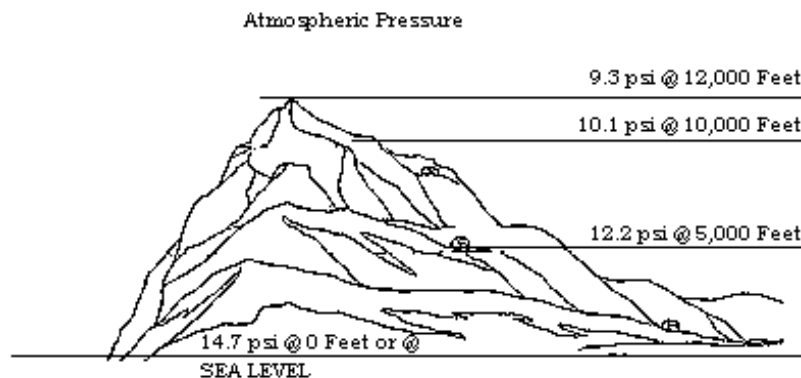

## GAUGE PRESSURE:

Gauge pressure is pounds per square inch that registers on a gauge and is written as psig (pounds per square inch gauge). Gauge pressure measures only the amount of pressure above (or below) atmospheric pressure. A gauge-pressure reading of 40 psig means that the pressure is 40 pounds per square inch greater than atmospheric pressure (Refer to figure 7).

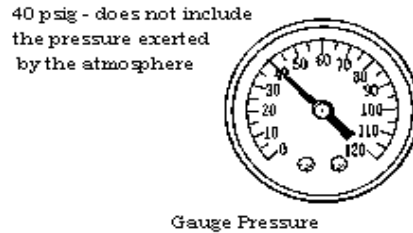

FIGURE - 7

**ABSOLUTE PRESSURE** is atmospheric pressure (14.7 psi) plus (or minus) gauge pressure. Pounds per square inch absolute is written as psia. Absolute pressure is the total pressure. For example, 44.7 psia (absolute pressure) = 14.7 psi (atmospheric pressure) + 30 psig (gauge pressure). Add the atmospheric pressure to the gauge reading to obtain absolute pressure. (Refer to figure 8)

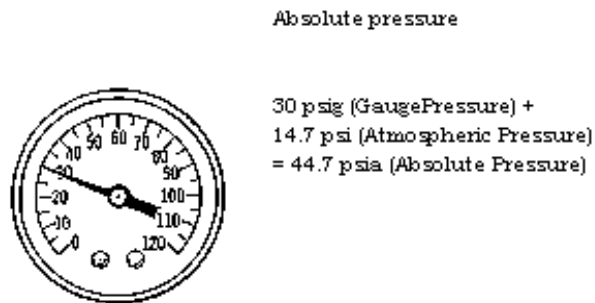

FIGURE - 8



Water weighs more than air, so it exerts a greater force (psi). A cubic foot of water (cu ft) weighs 62.4 lbs. Given, the formula of pressure (Pressure = Force / Area or  $P=F/A$ ), we can calculate the pressure water exerts on its container. Below one foot 12" by one foot 12" equals the area (length times width) or 144 square inches (in<sup>2</sup>). The force equals 62.4 lbs.

$$P = F/A$$

$$P = 62.4\text{lbs} / 144 \text{ in}^2$$

$$P = 0.433 \text{ lbs/in}^2 \text{ or } 0.433 \text{ psi}$$

The pressure exerted by a column of water 1 in. x 1 in. x 12 in high is **0.433** psig (gauge pressure). (Refer to figure 9)

The height of a column determines the amount of pressure (weight) that it exerts on the surface, or base. For example, a column of water:

- 1 ft high = 0.433 psig at the base.
- 2 ft high = 0.866 psig at the base.
- 3 ft high = 1.299 psig at the base.
- 100 ft high = 43.3 psig at the base.
- 27 3/4" = 1.0 psig at the base.
- 27 3/4" = 2.31ft.

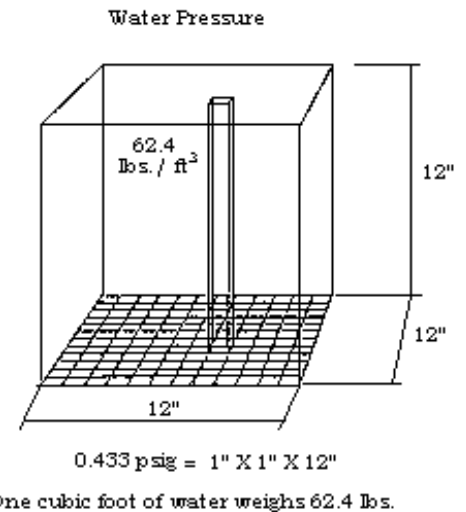

FIGURE – 9

Water pressure is sometimes referred to as pressure head, head, or feet of head.

- 1 ft of head, or 1 ft of water, is equal to a column of water.
- 1 ft (12in) high, or 0.433 psig. Therefore, 100 ft of head is equal to 43.3 psig.

The higher the column of water (as in an elevated tank or high-rise building) the higher the pressure at the base of the column.

# WATER: UNDER STATIC CONDITIONS

## Static pressure:

Static pressure is defined as the amount of gauge pressure that is measured during a static or **no** flow condition in the distribution system.

**Hydraulics** is the science that deals with fluids in motion and at rest. Obviously, fluids in motion exert pressure. The moving water of a river will propel rocks, tree limbs and boats. In fact, the pressure that moving water generates can be harnessed to create electricity. This concept is called kinetic energy. Fluids at rest (static fluids), however, also exert pressure. This concept is called potential energy. Water at rest exerts pressure because of the weight of the water and the earth's atmosphere.

## WATER MOVEMENT

Water movement is caused by pressure differentials. Pressure differentials can be created in a number of ways: differences in water weights, differences in atmospheric pressure, differences in water temperature, differences in velocity if there is water movement, and differences in mechanical forces. Water will stand still if the pressures in two pipes, tanks or vats are equal. Water will flow to the point of lowest pressure. Recall that pressure is just a measurement of force. The greater force will control movement, whether it is pushed or pulled.

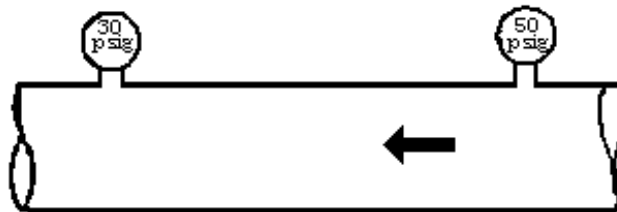

FIGURE - 10

Determining the direction of water movement in a pipe by comparing pressure gauge readings. Because water flows in the direction of lowest pressure or least resistance, the direction of flow between two given points can be determined by comparing pressure gauge readings at each end of the piping under observation. In the above illustration, water will flow from right to left.

## BACKSIPHONAGE

Back siphonage is the most common type of backflow. Back siphonage backflow can occur whenever a cross-connection exists and a negative pressure is generated in the potable water supply. The events that reduce potable supply pressure were listed under backpressure, e.g., fire fighting, water line flushing, etc. Any of these events could also cause a back siphonage backflow if the potable supply pressure is reduced below atmospheric pressure.

The following information depicts back siphonage backflow occurring at a restaurant, and is meant to illustrate just one of the many situations through which back siphonage backflow can occur. A temporary cross-connection is created in a restaurant kitchen when a hose connected to the potable water system is left in dirty mop water. This faucet just happens to be leaking. The mop water flows into the hose (just as water rises inside a straw that is partially submerged in water). When an automobile runs into a fire hydrant, causing it to burst, it suddenly creates a large loss of water, and therefore, a large decrease in water pressure. In fact, a negative pressure is created in the water line servicing the restaurant. Because the dirty mop water surrounding the hose is now less than atmospheric pressure, the mop water flows up the hose. The mop water flows through the leaky faucet and into the potable drinking water supply. Ultimately, the restaurant and the public system are supplied with dirty mop water. Any restaurant patron who eats the food prepared with the contaminated water could potentially be exposed to a number of pathogenic organisms. The type of temporary cross-connection illustrated in this example is common, because most people mistakenly believe that water cannot flow upward. See figure below.

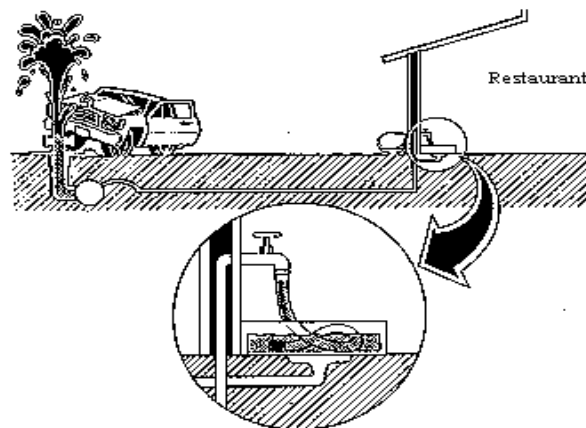

FIGURE - 11

## BACK PRESSURE

Backpressure is the most general and easiest to explain, type of backflow. It occurs whenever the pressure on the non-potable system is greater than the pressure on the potable water supply system. Backpressure is also referred to as **superior pressure**.

Any water demand that is larger than what the water purveyor can supply creates a reduction of pressure in the potable supply. Because a system will tend to maintain a constant pressure, a reduction in pressure on the supply side will cause the higher pressure on the customer side to equalize into the supply side. Examples of large water demands include fire fighting, water line flushing, and water line or fire hydrant leaks. If the water pressure on the potable side falls below that of a non-potable source, a backpressure backflow can occur.

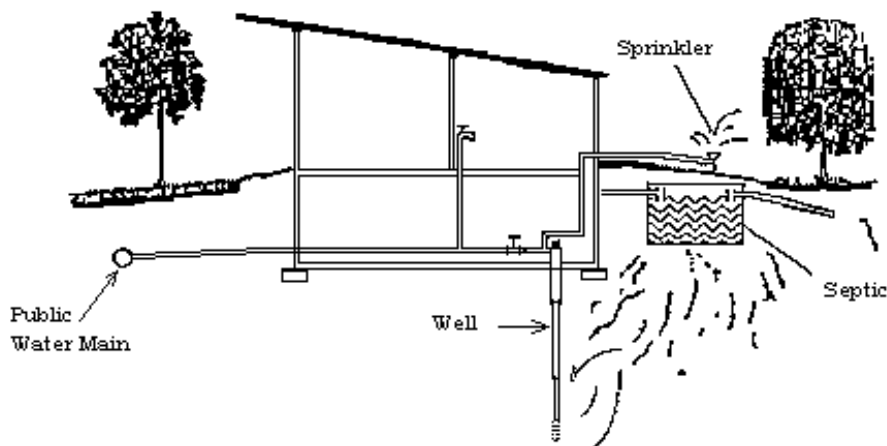

FIGURE - 12

**Figure - 12, a Cross-connection to an Irrigation Well-** Irrigation wells are commonly cross-connected to drinking water supplies. Because irrigation wells are not required to meet potable drinking water standards, the water from the irrigation well is considered non-potable. Irrigation wells have their own pumps; therefore, the non-potable irrigation water can maintain some constant pressure. The irrigation well pumps can overcome the pressure that is in the potable water line and create a greater pressure than line pressure. If a fire occurred, the potable water supply pressure would be reduced. If it falls below that maintained by the pump on the irrigation system, non-potable water will flow into the potable lines. In figure - 12, the well water has become contaminated with wastewater from the septic system.

# CAPILLARY ACTION

Contamination of potable water supplies can also occur as a result of capillary action. Capillary action is an unusual type of backflow. Unlike backpressure and back siphonage, water movement by capillary action appears to defy the laws of gravity. Capillary action allows water to move upward against the forces of gravity and atmospheric pressure. **Capillarity** is a type of attraction, consisting of two mutually attractive forces: adhesion and cohesion. Adhesion is the attraction between unlike molecules (such as water and plastic). Cohesion is the attraction between like molecules (for example, the attraction between water molecules). Together, these two forces allow water to move uphill. Capillary action can be illustrated using the straw example below. Water molecules are attracted to the plastic molecules of the straw by adhesion, and some water molecules can "creep" up the straw higher than the surrounding water level. Because of cohesion, other water molecules are attracted to these creeping molecules, and the water "flows" uphill along the surface of the straw (See Figure - 13 Below).

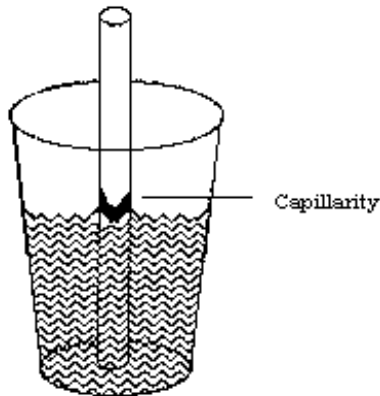

FIGURE - 13

**Capillarity in a Straw-** Capillarity, the attraction of like and unlike molecules, causes water to rise higher along the straw than the level of the water in the glass.

**Capillarity is not as common as backpressure and back siphonage, but must be guarded against.**

## **SUMMARY**

Understanding how and why backflows occur is essential if they are to be prevented. To prevent backflow, it is necessary to identify the hydraulic conditions that will create them. Pressure differentials between potable water supplies and non-potable supplies are the cause of backflow events. Capillary action, to a lesser extent, can also cause the reverse movement of water and thus allow polluted or contaminated water to enter a potable water supply.

# METHODS FOR PREVENTING BACKFLOW

## BACKFLOW PREVENTION METHODS

The provision of an **air gap** provides the only absolute method for preventing backflows, since the air gap eliminates the cross connections. An air gap is simply the physical separation of the potable water supply from all sources of contamination or pollution. An air gap is the simplest (since unlike mechanical backflow assemblies, an air gap does not require any mechanical parts to function), and therefore, the least expensive method for preventing backflows. However, for an air gap to function dependably, certain specifications must be met.

**There must be a minimum distance of (2) two times the inside diameter of the water supply outlet between the water supply outlet and the flood rim level of any receptacle that could contain a hazardous substance.**

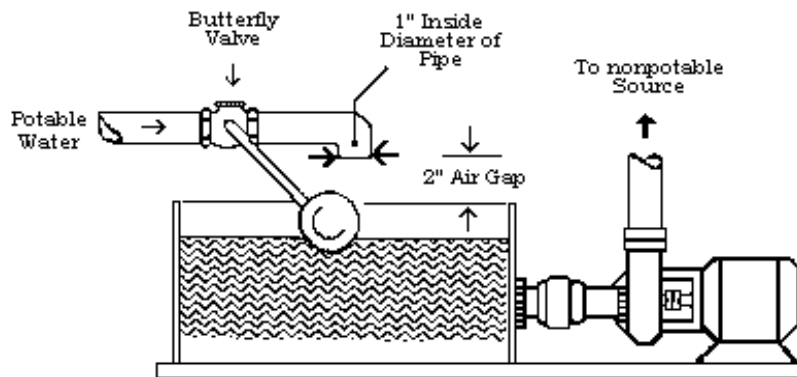

FIGURE - 14

Figure - 14 above shows an **Air Gap** being employed at a **Booster Pump**. Because the inside diameter of the water supply is one inch, a two inch air gap must be provided between the water supply outlet and the flood rim of the container. **An absolute minimum of one inch must always be maintained** between the water supply outlet and the flood rim level (not the overflow) of the fixture being served.

If a pipe is cut on a diagonal, the air gap is measured from the mid point of the diagonal cut (See Figure - 15 Below).

FIGURE - 15

### Air Gap Requirement with a Diagonal Cut Supply Outlet

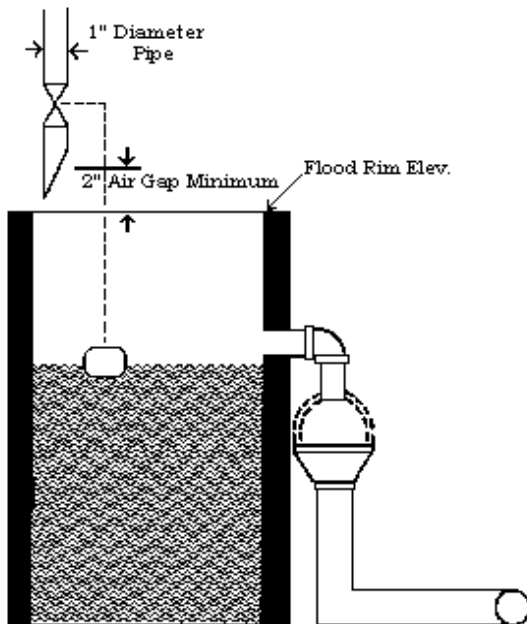

A one-inch water supply outlet that is cut on a diagonal must have a minimum of a two-inch air gap, measured from the midpoint of the cut to the top of the flood rim level. The minimum separation is required because water will actually rise higher than the flood rim level of the container. This is due to the surface tension of water. (Try overfilling a glass just a little, the water level can actually get higher than the glass itself.) Also, if a very strong vacuum is created in a water line, suction can draw water up through an air gap if it is insufficient.



# BACKFLOW PREVENTERS

## MECHANICAL BACKFLOW PREVENTERS

Before discussing the different types of mechanical backflow preventers, it is important that the terms "device" and "assembly" be clarified. The term **device** refers to the backflow prevention mechanism only. It does not include the shut-off valves located on each end of the backflow preventer. An **assembly** is the entire backflow prevention unit, including not only the mechanism that actually prevents backflow, but also the shut-off valves and test cocks.

To be an approved assembly, the backflow assembly must be shipped from the manufacturer as one unit. It should not be assembled in-house. However, this does not mean that the whole assembly must be replaced whenever a part wears out. Worn out parts should be replaced with "approved" parts.

A backflow prevention assembly must have shut-off valves that are of the full-flow type (Full-flow potential is an essential factor). The purpose is to eliminate unnecessary reduction in pressure, since backflow preventers themselves already reduce line pressure. The shut-off valves must be "resilient seated", meaning, capable of withstanding shock without permanent deformation or rupture.

The operating stem on a ball valve type test cock must be "blow-out proof" to ensure that the stem does not come out of the body.

The assembly itself is also required to be labeled with the following minimum markings.

- 1) Manufacture's symbol or name
- 2) Type of assembly
- 3) Size and model number
- 4) Rated working water pressure
- 5) Rated working water temperature
- 6) Direction of flow.

To be "approved", a backflow preventer must be in-line testable and repairable. In other words, the backflow preventer must be situated in a permanent location on the potable water line and still have the ease of testing and maintenance with out requiring removal.

# APPROVAL of BACKFLOW PREVENTION DEVICES

Generally, the authority (municipality/water purveyor) having jurisdiction will select, or adopt a basis for design from criteria established by a recognized agency. Some of these agencies include:

USC FCCC HR (University of Southern California, Foundation for Cross-Connection Control and Hydraulic Research)

AWWA (American Water Works Association)

ASSE (American Society of Sanitary Engineering)

FM (Factory Mutual)

UL (Underwriters Laboratories)

Specifications developed by USC are widely used throughout the nation. However, AWWA specifications are also used (often in conjunction with USC approvals). Many authorities may require approval by two or more agencies. Other agencies listing approval of devices may include:

CSA (Canadian Standards Association)

UPC (Uniform Plumbing Code)

ANSI (American National Standards Institute)

SBCCI (Southern Building Code Congress International)

ASME (American Society of Mechanical Engineers)

The authority having jurisdiction may require additional specifications in addition to those required by other agencies. For example: some may require bronze bodies through 3" sizes, some may require union ends, etc. Primarily, these decisions are based upon what the authority having jurisdiction feels will best suit the needs of their system.

## PRESSURE VACUUM BREAKER:

Pressure vacuum breakers (PVB) are very similar to atmospheric vacuum breakers in design, However, their are a few notable differences, the PVB is classified as an assembly instead of a device, as it has two approved shutoff valves and two approved test cocks. Also, the air inlet valve and the check valve operate independently of each other, and are both spring loaded (SEE FIGURE BELOW).

FIGURE - 16

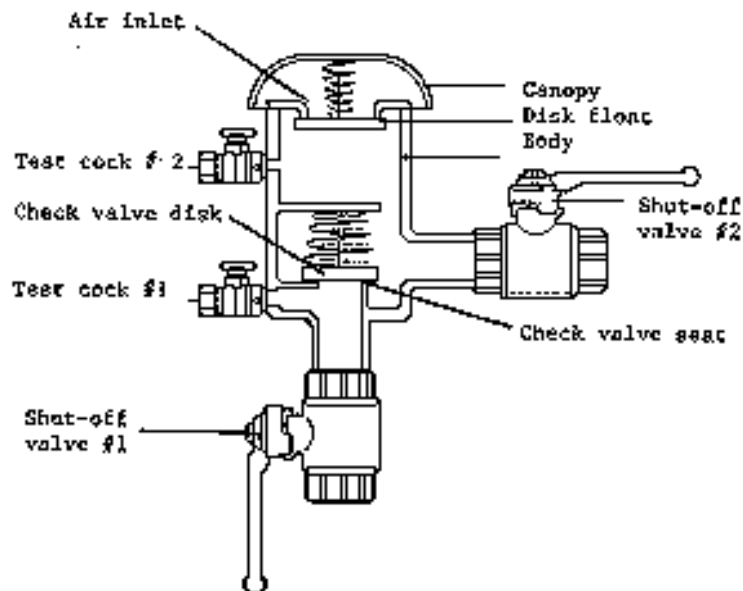

The pressure vacuum breaker can be used under non-health or health hazard conditions, but is approved for protection against back siphonage only. Generally, the PVB is used for isolation purposes. For instance, it is commonly used as protection on lawn irrigation systems. Unlike the AVB, The PVB can be used where it will be subjected to continuous pressure. It is not approved in a condition where it can be subjected to back pressure. The installation specifications require the pressure vacuum breaker to be installed 12" above the highest point in the system. However, unlike the AVB it is acceptable to have a shut-off valve located down stream of the assembly.

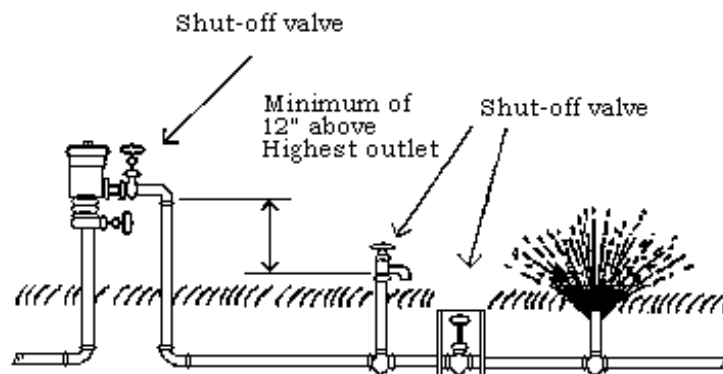

FIGURE - 17

## DOUBLE CHECK VALVE ASSEMBLY:

A double check valve assembly is basically what its name implies; a device composed of two (2) independently acting, approved check valves, including tightly closing approved shutoff valves located at each end of the device and 4 suitable connections (test cocks) for testing the water tightness of each valve.

The check valves will stay closed unless forced open by water in the normal direction of flow. They should hold tight against 1 psi in the normal direction of flow and the maximum pressure drop allowed across the assembly is 10 psi. This is significant to engineers who design plans for fire sprinklers.

Double check valves provide adequate protection against both types of backflow – back siphonage and backpressure. They can also be subjected to continuous pressure. In the rare event that both check valves are fouled at the same time. The assembly no longer provides protection against backflow. For this reason, double check valves are only approved for non-hazard situations.

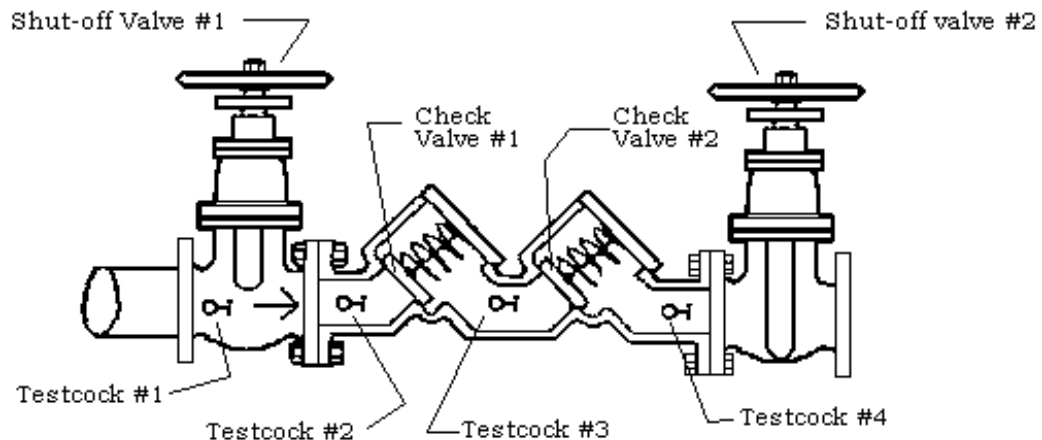

FIGURE - 18

It is recommended that DCVAs should be installed at a minimum of 12 inches and at a maximum of 30 inches (depending on the local authority) above the ground, drainage system or flood elevation. Installation in a pit or vault is allowed if the pit is not subject to flooding as required by local authority. **However, it is not recommended.**

## **REDUCED PRESSURE PRINCIPLE ASSEMBLY:**

A reduced pressure principle assembly is a device containing within its structure a minimum of two (2) independently acting, approved check valves, and coupled with an automatically operating pressure differential relief valve. The first check valve reduces the supply pressure a predetermined amount so that during normal flow and at cessation of normal flow, the pressure between the checks shall be less than the supply pressure. In the event there is leakage from either check valve, the differential relief valve, by discharge to atmosphere, shall operate to maintain a lower pressure between the checks than the supply pressure. The unit shall include tightly closing shut-off valves located at each end of the device, and each device shall be fitted with properly located test cocks.

The **RP is effective against both backpressure and back siphonage, and is adequate protection against both health and non-health hazards.** An RP can be subjected to continuous pressure. It is the most versatile backflow preventer. The only other form of backflow prevention that can be used in all different situations is the air gap. The air gap has one major difference, a total loss of system pressure. The RP does not cause a significant reduction in pressure; however, being a mechanical assembly, it does have some disadvantages, it is considerably more expensive than an air gap, and it requires maintenance and testing at least annually.

FIGURE – 19

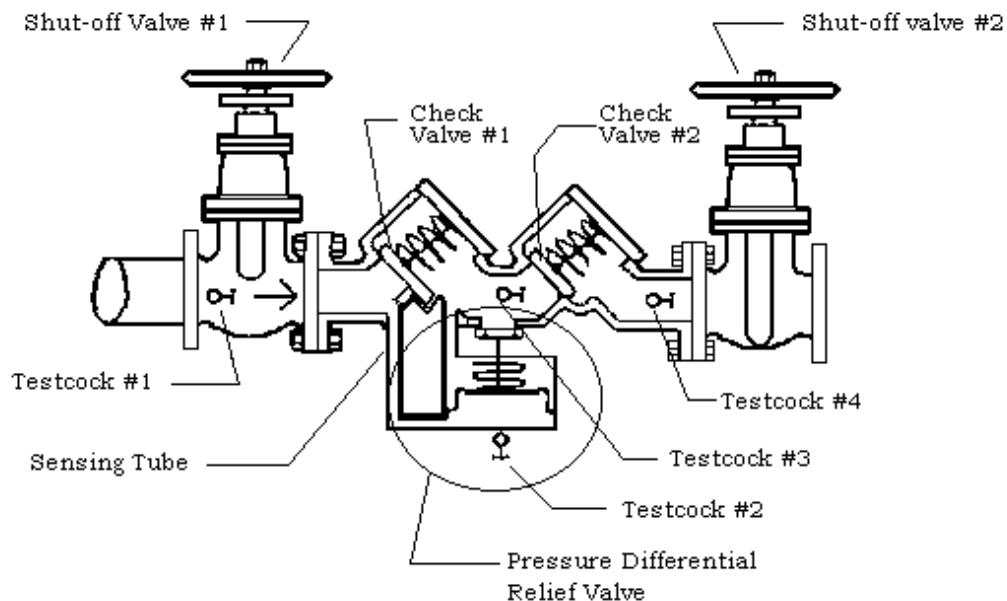

## Unapproved Devices:

The devices listed below do not provide adequate protection against backflow and should not be used. They are listed so students will be able to recognize such installations and take appropriate action to install an approved, reliable device.

A **Barometric Loop** consists of an elevated loop in the piping system that is at least 34 ft high. Under normal conditions, back siphonage is prevented because a **perfect vacuum at sea level cannot raise a column of water more than 33.9 ft**. However, backpressure in a non-potable supply connected to a boiler or pump will allow backflow to occur through the barometric loop. These devices are no longer installed, since they are cumbersome and are not considered reliable. Nevertheless, in some areas, it is still being used as a backflow prevention device.

Barometric Loop - Projects Only Against Backsiphonage

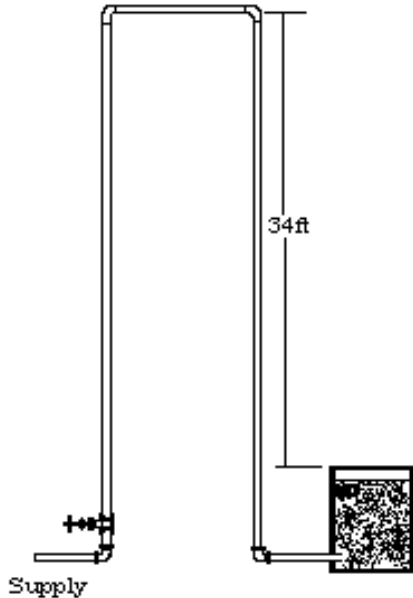
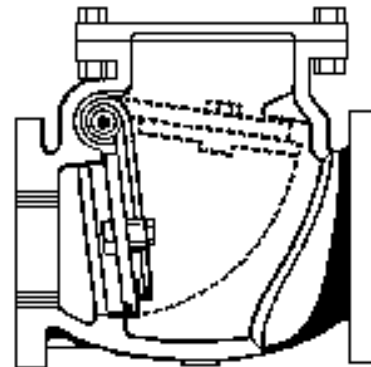

FIGURE – 20

FIGURE – 21 **Single Check Valve:**

Single Check Valve - Not a Backflow Preventer



Single check valves operate as a simple barrier in a water pipe. A clapper or gate is operated mechanically to prevent flow through the pipe. Single check valves do not provide adequate protection against backflow because they cannot be visually inspected and have no backup mechanism that operates in the event the valve becomes fouled.

Spools, swing connections, and changeover devices were once installed to provide access to auxiliary supplies used for fire-fighting purposes. However, these illegal connections created a direct cross-connection (since they offered no protection for the potable system). In addition, utilization of these connections required that the changeover device be manually switched from one system to the other, and left the chore of disinfecting the potable system after each use. To correct these shortcomings, spools, swing connections, and changeover devices should be removed from the system and replaced with approved backflow-prevention devices.

Change-Over Device - Can Create a Direct Cross Connection

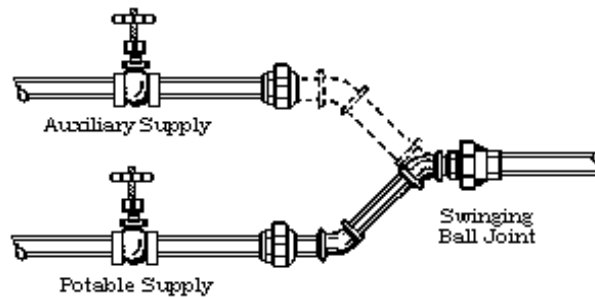

FIGURE - 22



## ATMOSPHERIC VACUUM BREAKER:

The atmospheric vacuum breaker is the simplest type of mechanical backflow preventer. However, since the atmospheric breaker cannot be fully tested, it is not approved by the Foundation for Cross Connection Control and Hydraulic Research (FCCCHR). Many of these devices that are on the market have been tested and approved by the Los Angeles City Mechanical Testing Laboratory, and are included in the approval list issued by FCCCHR.

An atmospheric vacuum breaker consists of a float type check valve and an air inlet port. These devices **do not have test cocks or shutoff valves**.

When water is flowing through the device in the proper direction, the float seals the air inlet port, preventing air from entering the system. With no water flow, or reversed flow through the chamber, the float will fall, forming a check valve. At the same time, air entering the system through the air-inlet port breaks the vacuum and prevents back siphonage.

Atmospheric vacuum breakers cannot be installed where they will be subject to continuous pressure. The Atmospheric vacuum breaker can be used under non-health or health hazard conditions, but is approved for protection against back siphonage only. Atmospheric vacuum breakers are generally installed on hose connections, laboratory faucets, toilet tanks and flushometer valves.

Atmospheric vacuum breakers must be installed 6in. above the highest point of the downstream outlet (or 6in. above the point of highest usage), and must be installed downstream of all valves and pumps. These devices can be visually inspected to determine whether or not the air inlet port opens when an upstream valve is closed.

FIGURE - 23

Typical Installation of Atmospheric Vacuum Breaker

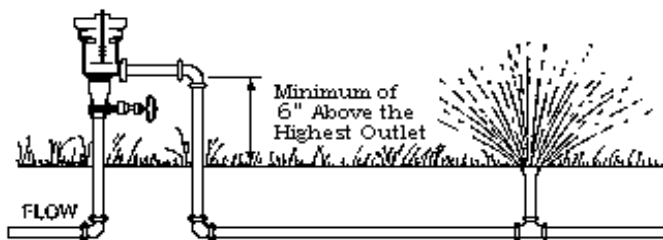

Absolutely no means to shut off allowed on discharge side of the Atmospheric Vacuum Breaker

- An atmospheric vacuum breaker must not have any shut-off valves located downstream of the device.

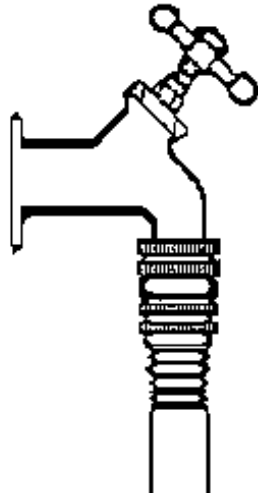

**FIGURE - 24 Hose Connection (Bib) Vacuum Breaker**

ASSE No. 1011 outlines the application for a hose connection vacuum breaker. It is commonly used as a form of backflow prevention at threaded faucets. The hose bib vacuum breaker is approved backflow protection in a condition of health or non-health hazards. The device provides protection against low head backpressure backflow equal to or less than 4.33psi and back siphonage. This device allows for low head backpressure, where the only source of low head backpressure comes from an elevated hose equal to or less than 10 feet in height. Low head backpressure mentioned above only applies to the hose connection vacuum breaker. This low head pressure does not apply to the atmospheric vacuum breaker.

The Hose connection vacuum breaker consists of a spring load check valve, which is loaded, closed. In addition to the check valve the hose connection vacuum breaker has a spring loaded atmospheric vent valve loaded open while not under pressure. When under pressure the hose connection vacuum breaker vent valve is close which will not allow water to escape or leak. When flow is required the check valve will open allowing water to enter a hose. This type of protection is not intended for continuous use. It is only allowed to be used for extended time periods of no more than 12 hours during any 24 hour period. Sizes include  $\frac{1}{2}$ ",  $\frac{3}{4}$ " and 1".

## SUMMARY CHART OF BACKFLOW PREVENTION METHODS

	AIR GAP ANSI A112.1.2	AVB ASSE 1001	PVB ASSE 1020	DCVA ASSE 1015	RP ASSE 1013
Health Hazard/Non-Health Hazard	H	H	H	N	H
Back pressure/Back siphonage	Bp/Bs	Bs	Bs	Bp/Bs	Bp/Bs
Pressure Loss Significant	Yes	No	No	No*	No*
Continuous Pressure Allowed	Yes	No	Yes	Yes	Yes
Vents to Atmosphere	Yes	Yes	Yes	No	Yes
Pit/Chamber Installation Acceptable	No	No	No	Yes	No
Vertical Installations Allowed	Yes	No	No	Maybe	Maybe
Isolation/Containment (Commonly)	I & C	I	I	C	C
Parallel Installation Common	No	No	No	Yes	Yes

Continuous pressure - operating under pressure for 12 hours or more.

\* The maximum pressure loss allowed on a DCVA is 10psi. The pressure loss through a RP assembly is approximately 7-14psi.

## SUMMARY

Preventing the backflow of contaminants in the potable water system is absolutely essential if health and property are to be protected. The best means of precluding backflow is by eliminating cross-connections through the use of a proper air gap as reviewed in this study guide. This guide has also introduced the backflow prevention assemblies and devices that can be employed to prevent backflow when cross-connections are necessary. In these cases, backflow preventers can be installed to reduce the chance of a backflow occurring. The choice of method employed will depend upon perceived level of hazard and the type of backflow (back pressure or back siphonage) that may occur.

Health hazard situations require an Air Gap, Atmospheric Vacuum Breaker, a Pressure Vacuum Breaker, or a Reduced Pressure Principle Assembly. However, only an Air Gap and RP are suitable for a situation that may involve backpressure, thus, an AVB and PVB are generally only used for isolation purposes. Non-Health hazard situations in which backpressure are not anticipated: can be handled by a double check valve assembly or any of the previous methods. If the potential for backpressure exists, the Air Gap, RP or the DCVA can be utilized.

Cost can be a concern when choosing a backflow preventer, AVBs and PVBs are inexpensive, while RPs and DCVAs involve a larger investment. However, it should be stressed that the hazard level and anticipated hydraulic conditions at each cross-connection **must** take priority over cost when deciding on a method of backflow prevention.

This page is reserved for student notes:

## SUMMARY OF BACKFLOW PREVENTION METHODS

	AIR GAP ANSI A112.1.2	AVB ASSE 1001	PVB ASSE 1020	DCVA ASSE 1015	RP ASSE 1013
<b>Health Hazard/Non-Health Hazard</b>	H	H	H	N	H
<b>Back pressure/Back siphonage</b>	Bp/Bs	Bs	Bs	Bp/Bs	Bp/Bs
Pressure Loss Significant	Yes	No	No	No*	No*
Continuous Pressure Allowed	Yes	No	Yes	Yes	Yes
Vents to Atmosphere	Yes	Yes	Yes	No	Yes
Pit/Chamber Installation Acceptable	No	No	No	Yes	No
Vertical Installations Allowed	Yes	No	No	Maybe	Maybe
<b>Isolation/Containment (Commonly)</b>	I & C	I	I	C	C
Parallel Installation Common	No	No	No	Yes	Yes

Continuous pressure - operating under pressure for 12 hours or more.

- \* The maximum pressure loss allowed on a DCVA is 10psi. The pressure loss through a RP assembly is approximately 7-14psi.

## SUMMARY OF BACKFLOW PREVENTION METHODS

	AIR GAP ANSI A112.1.2	AVB ASSE 1001	PVB ASSE 1020	DCVA ASSE 1015	RP ASSE 1013
Health Hazard/ <b>Non-Health Hazard</b>					
<b>Back pressure/Back siphonage</b>					
Pressure Loss Significant					
Continuous Pressure Allowed					
Vents to Atmosphere					
Pit/Chamber Installation Acceptable					
Vertical Installations Allowed					
<b>Isolation/Containment (Commonly)</b>					
Parallel Installation Common					

Continuous pressure - operating under pressure for 12 hours or more.

- \* The maximum pressure loss allowed on a DCVA is 10psi. The pressure loss through a RP assembly is approximately 7-14psi.

## SUMMARY OF APPLICATIONS FOR INTERNAL BACKFLOW PROTECTION

	DUAL CHECK ASSE 1024	BFP W/ INTERMEDIATE ATMOSPHERIC VENT ASSE 1012	DUAL CHECK for CARBONATED BEVERAGE DISPENSERS ASSE 1032	LABORATORY FAUCET VACUUM BREAKER ASSE 1035	HOSE BIB VACUUM BREAKER ASSE 1011
<b>Health Hazard/Non-Health Hazard</b>	N	N	N	N & H	N & H
<b>Back pressure/Back siphonage</b>	Bp & Bs	Bp & Bs	Bp & Bs	Bs	Bs
Pressure Loss Significant	No	No	No	No	No
Continuous Pressure Allowed	Yes	Yes	Yes	No	No
Vents to Atmosphere	No	Yes	No	Yes	Yes

Continuous pressure – operating under pressure for 12 hours or more.

This page is reserved for student notes:



## GLOSSARY

**ABSOLUTE PRESSURE** – The total pressure; gauge pressure plus atmospheric pressure. Absolute pressure is generally measured in pounds per square inch (psi).

**AIR GAP SEPARATION** – An unobstructed vertical distance through the atmosphere between the lowest opening from any pipe or faucet supplying water to a tank, plumbing fixture, or other device and the flood level rim of the receptacle. An approved air-gap vertical separation shall be at least double the diameter of the supply pipe. In no case shall the air-gap be less than one (1) inch.

**APPROVED** – Certified in writing by the Director as an acceptable device or methodology for the purpose of backflow prevention.

**ATMOSPHERIC PRESSURE** – The pressure exerted by the weight of the atmosphere (14.7 psi at sea level). As the elevation above sea level increases, the atmospheric pressure decreases.

**BACKFLOW** – The term “backflow” shall mean the undesirable reversal of flow of water or mixtures of water and other liquids, gases or other substances into the distribution pipes of the potable supply of water from any source or sources.

**BACKFLOW PREVENTION ASSEMBLY** – An approved effective device or method used to prevent backflow from occurring in the potable water supply which may be greater than the pressure on the public water supply and may result in a backflow.

**BACKPRESSURE** – Any pressure on any source of water other than the public water supply, which may be greater than the pressure on the public water supply and may result in a backflow.

**BACK SIPHONAGE** – Any circumstance in which the pressure on the public water supply may be reduced to the point that the elevation and atmospheric pressure on a source of water other than the public water supply may result in a pressure to be greater than the pressure on the public water supply and may result in a backflow.

**BYPASS** – Any arrangement of pipes, plumbing, or hoses designed to divert the flow around an installed device through which the flow normally passes.

**NOTE:** Bypass cannot be allowed around any backflow prevention device unless a device of equal standards is installed in the bypass line.

**CERTIFIED TESTER** – A person who has proven his/her competency to test, repair, overhaul and make reports on backflow prevention devices as evidenced by certification of successful completion of a training program approved by the Director.

**CHEMICAL** – A substance obtained by a chemical process or used for producing a chemical reaction.

**CONSUMER** – Any person, firm, or corporation responsible for any property at which water from the City public water supply is received. In the absence of other parties or the failure of other parties to accept the responsibilities herein set forth, the owner of record shall be ultimately responsible.

**CONTAINMENT** – Preventing the impairment of the potable water supply by installing an approved backflow prevention device at the service connection.

**CONTAMINANT** – See POISON

**CONTAMINATION** – The presence of any foreign substance (organic, inorganic, radiological or biological) in water that tends to degrade its quality so as to constitute a hazard or impair the usefulness of water.

**CONTINUOUS PRESSURE** – A condition in which upstream pressure is applied continuously (more than 12 hours) to a device or fixture. Continuous pressure can cause mechanical parts within a device to freeze.

**CROSS CONNECTION** – Any physical connection between a potable water supply system and any other piping water, sewer fixture, container, or device, whereby water or other liquids, mixtures, or substances may flow into or enter the potable water supply system.

**CROSS CONNECTION CONTROL** – The use of devices, methods, and procedures to prevent contamination of a potable water supply through cross connection.

**DEGREE OF HAZARD** – The evaluation of the potential hazard (see definition of hazard) as defined in state.

**DIRECT CONNECTION** – Any arrangement of pipes, fixtures, or devices connecting a potable water supply directly to a non-potable source (i.e., a boiler feed line).

**DIRECTOR** – The owner or official custodian of a public water system.

**DISTRIBUTION SYSTEM** – All pipes, fittings, and fixtures used to convey liquid from one point to another.

**DOUBLE CHECK VALVE ASSEMBLY** – A device composed of two (2) single, independently acting, approved check valves, including tightly closing shutoff valves located at each end of the device and suitable connections for testing the water-tightness of each check valve.

**FLOOD LEVEL RIM** – That level from which liquid in plumbing fixtures, appliances, tanks or vats will overflow to the floor, when all drain and overflow openings built into the equipment are obstructed.

**GAUGE PRESSURE** – Pounds per square inch (psi) that are registered on a gauge. Gauge pressure measures only the amount of pressure above (or below) atmospheric pressure.

**HEALTH HAZARD** – An actual or potential threat of contamination or pollution of a physical or toxic nature to the public water system or the consumers potable water system to such a degree or intensity that there would be a danger to health.

**INDIRECT CONNECTION** – Any arrangement of pipes, fittings, or fixtures that indirectly connects a potable water supply to a non-potable supply (i.e., a submerged inlet to a tank).

**ISOLATION** - The act of confining a localized hazard within a plumbing or distribution system by installing approved backflow prevention devices.

**LIABILITY** – Obligated by law, or responsible for.

**NEGATIVE PRESSURE** – Pressure that is less than atmospheric; negative pressure in a pipe can induce a partial vacuum that can siphon non-potable liquids into the potable distribution system.

**NON-HEALTH HAZARD** – An actual or potential threat to the physical properties of the public or the consumer's potable water system, or of a contamination which would have a protracted effect on the quality of the potable water system.

**NON-POTABLE** – Any liquid that is not considered safe for human consumption.

**NON-TOXIC** – Not poisonous; a substance that will not cause illness or discomfort if consumed.

**PHYSICAL DISCONNECTION (SEPARATION)** – Removal of pipes, fittings, or fixtures that connect a potable water supply to a non-potable system or one of questionable quality.

**PLUMBING** – Any arrangement of pipes, fittings, fixtures, and devices for purpose of moving liquids from one point to another, generally within a single structure.

**POISON** – A substance that can kill, injure, or impair a living organism. Poison / Contaminants are considered health hazards.

**POLLUTANT** - A substance that deteriorates the aesthetic quality of water or other materials but is not harmful to health. Pollutants are considered non-health hazards.

**POLLUTION** – The term "pollution" shall mean an impairment of the quality of the water to a degree, which does not create a hazard to health but will adversely and unreasonably affect the aesthetic qualities of such waters for domestic use.

**POTABLE WATER** – Water from any source which has been investigated by the Health Department and which has been approved for human consumption.

**PRESSURE** – The weight (of air, water, etc.) exerted on a surface, generally expressed as pounds per square inch (psi).

**PRESSURE VACUUM BREAKER** – A device consisting of one or two independently operating, spring loaded check valves and an independently operating, spring-loaded air inlet valve designed to prevent back siphonage.

**REDUCED PRESSURE BACKFLOW PREVENTION ASSEMBLY** – An approved device containing within its structure a minimum of two (2) independently acting, approved check valves, together with an automatically operating pressure relief valve. The first check valve reduces the supply pressure a predetermined amount so that during normal flow and a cessation of normal flow, the pressure between the checks shall be less than the supply pressure. The unit shall include tightly closing shut-off valves located at each end of the device and each device shall be fitted with properly located test cocks.

**REFUSAL OF SERVICE (SHUT OFF POLICY)** - A formal policy adopted by a governing board to enable a utility to refuse or discontinue service where a known hazard exists and corrective measures are not undertaken.

**REGULATING AGENCY** – Any local, state, or federal authority given the power to issue rules or regulations having the force of law for the purpose of providing uniformity in details and procedures.

**RELIEF VALVE** – A device designed to release air from a pipeline, or introduce air into a line if the internal pressure drops below atmospheric pressure.

**SERVICE CONNECTIONS** – The terminal end of a service connection from the public potable water system (i.e., where the Director loses jurisdiction and sanitary control over the water at its point of delivery to the consumer's water).

**SUBMERGED INLET** – An arrangement of pipes, fittings, or devices that introduces water into a non-potable system below the flood-level rim of a receptacle.

**SUPERIOR PRESSURE** – See BACK PRESSURE.

**TEST COCK** – An appurtenance on a device or valve used for testing the device.

**THERMAL EXPANSION** – A term used to explain a change in pressure due to a change in temperature. In a closed water system, as the temperature increases the pressure will increase.

**TOXIC** – Poisonous; a substance capable of causing injury or death.

**VACUUM BREAKER (ATMOSPHERIC TYPE)** – A device used to prevent back siphonage, which is designed so as not to be subjected to static line pressure.

**VACUUM BREAKER (PRESSURE TYPE)** – A device suitable for continuous pressure, to be used to provide protection against back siphonage.

**VENTURI PRINCIPLE** – As the velocity (speed) of water increases, the pressure decreases. The Venturi principle can induce a vacuum (sub-atmospheric pressure condition) in a distribution system.

**WATERBORNE DISEASE** – Any disease that is capable of being transmitted through water (i.e., typhoid, polio, and giardiasis).

**WATER SUPPLY (APPROVED)** – The term approved water supply shall mean any public potable water supply, which has been investigated and approved by the North Carolina Department of Human Resources. The system must be operating under a valid health permit. In determining what constitutes an approved water supply, the Division of Health Services has reserved the final judgment as to its safety and potability.

**WATER SUPPLY (UNAPPROVED)** – The term unapproved water supply shall mean a water supply, which has not been approved for human consumption by the North Carolina Department of Human Resources.

**WATER SUPPLIER (PURVEYOR)** – An organization that is engaged in producing and/or distributing water for domestic use.

**North Carolina Section AWWA/WEA Approved  
Backflow Prevention Assembly Field Test Procedures**

**Attachments:**

**(Five valve gage procedure)**

**Reduced Pressure Principle Assembly (RP) Test Procedures**

**RP Trouble Shooting**

**Pressure Vacuum Breaker (PVB) Test Procedures**

**PVB Trouble Shooting**

**Double Check Valve Assembly (DC) Test Procedures**

**DC Trouble Shooting**

**(Two valve gage procedure)**

**Reduced Pressure Principle Assembly (RP) Test Procedures**

**Pressure Vacuum Breaker (PVB) Test Procedures**

**Double Check Valve Assembly (DC) Test Procedures**

**(Three valve gage procedure)**

**Reduced Pressure Principle Assembly (RP) Test Procedures**

**Pressure Vacuum Breaker (PVB) Test Procedures**

**Double Check Valve Assembly (DC) Test Procedures**